



**EchoPump
LU60 Series
Owner's Manual
06/17/03**



Specifications

Sensor	Enclosure rating: NEMA 4X (IP65)	Current flow: Isolated sinking
Range: 0.5' to 33' (15 cm to 10m)	installed height: 4.1" (10.4 cm) above tank process mount	Signal invert: 4-20 or 20-4 mA
Accuracy: ± 0.25% of span in air	Encl. material: PP, UL94V0	Calibration: Digital, push button
Resolution: 0.125" (3 mm)	Trans. material: PVDF Kynar®	Linearization: 2-16 points
Beam width: 8" conical	Mount. threads: 2" NPT (2" G)	Contact type: (5) SPDT relay, latching
Dead band: 0.5' (15 cm)	Mount. gasket: Viton® (G version only)	Contact rating: 250 VAC @ 10A
Process temp.: F: -40° to 140° C: -40° to 60°	Conduit entrance: Single, 1/2" NPT	Contact fail-safety: Reverts to de-energized state during echo-loss
Temp. comp.: Automatic	Controller	LED indication: Power & relay status
Electronics temp.: F: -20° to 140° C: -4° to 60°	Display type: 2-line LCD, 16-digit	Electronics temp.: F: -40° to 140° C: -40° to 60°
Pressure: 30 psi (2 bar) @ 25° C, derated @ 1.667 psi (.113 bar) per °C. above 25° C.	Display units: Distance: inch/cm Volume: gallon/liter	Enclosure: NEMA 4X (IP65)
Rec. cable: (5) conductor, shielded	Memory: Non-volatile	Encl. material: Polycarbonate
Cable length: 150' (48m) max.	Supply voltage: 120/240 VAC @ 50-60 Hz.	Conduit entrance: 1/2" knock outs
	Signal output: 4-20 mA, two-wire	Classification: General purpose
		CE compliance: EN 50062-2 immunity EN 55011 emission EN 61010-1 safety

Dimensions



Safety Precautions:

About this Manual:

PLEASE READ THE ENTIRE MANUAL PRIOR TO INSTALLING OR USING THIS PRODUCT. This manual includes information on the transmitter for the EchoPump™ Ultrasonic Level Pump Controller from FLOWLINE: LU60-1001 and LU60-1061. Please refer to the part number located on the controller label to verify the exact model, which you have purchased.

User's Responsibility for Safety:

FLOWLINE manufactures a wide range of liquid level sensors and technologies. While each of these sensors is designed to operate in a wide variety of applications, it is the user's responsibility to select a sensor model that is appropriate for the application, install it properly, perform tests of the installed system, and maintain all components. The failure to do so could result in property damage or serious injury.

Proper Installation and Handling:

Because this is an electrically operated device, only properly trained staff should install and/or repair this product. Use a proper sealant with all installations. Note: Always install the 2" Viton gasket with the LU60-1061. The G threaded version of the transmitter will not seal unless the gasket is installed properly. Never over tighten the transmitter within the fitting. Always check for leaks prior to system start-up.

Wiring and Electrical:

All power for the transmitter will be received from the controller. Electrical wiring should be performed in accordance with all applicable national, state, and local codes.

Material Compatibility:

The transmitters enclosure is made of Polypropylene (PP). The transducer is made of Polyvinylidene Fluoride (PVDF). The controller is made of Polycarbonate. Make sure that the model, which you have selected, is chemically compatible with the application liquids it will contact.

Enclosure:

While the transmitter and controller housings are liquid-resistant when installed properly, they are not designed to be immersed. It should be mounted in such a way that the enclosure and diaphragm do not come into contact with fluid.

Make a Fail-Safe System:

Design a fail-safe system that accommodates the possibility of transmitter or power failure. In critical applications, FLOWLINE recommends the use of redundant backup systems and alarms in addition to the primary system.

Flammable, Explosive and Hazardous Applications:

The transmitter should not be used within flammable or explosive applications.



Warranty

Flowline warrants to the original purchaser of its products that such products will be free from defects in material and workmanship under normal use and service for a period, which is equal to the shorter of one year from the date of purchase of such products or two years from the date of manufacture of such products.

This warranty covers only those components of the products, which are non-moving and not subject to normal wear. Moreover, products which are modified or altered, and electrical cables, which are cut to length during installation, are not covered by this warranty.

Flowline's obligation under this warranty is solely and exclusively limited to the repair or replacement, at Flowline's option, of the products (or components thereof), which Flowline's examination proves to its satisfaction to be defective. FLOWLINE SHALL HAVE NO OBLIGATION FOR CONSEQUENTIAL DAMAGES TO PERSONAL OR REAL PROPERTY, OR FOR INJURY TO ANY PERSON.

This warranty does not apply to products, which have been subject to electrical or chemical damage due to improper use, accident, negligence, abuse or misuse. Abuse shall be assumed when indicated by electrical damage to relays, reed switches or other components. The warranty does not apply to products, which are damaged during shipment back to Flowline's factory or designated service center or are returned without the original casing on the products. Moreover, this warranty becomes immediately null and void if anyone other than service personnel authorized by Flowline attempts to repair the defective products.

Products which are thought to be defective must be shipped prepaid and insured to Flowline's factory or a designated service center (the identity and address of which will be provided upon request) within 30 days of the discovery of the defect. Such defective products must be accompanied by proof of the date of purchase.

Flowline further reserves the right to unilaterally wave this warranty and to dispose of any product returned to Flowline where:

- a. There is evidence of a potentially hazardous material present with product.*
- b. The product has remained unclaimed at Flowline for longer than 30 days after dutifully requesting disposition of the product.*

THERE ARE NO WARRANTIES, WHICH EXTEND BEYOND THE DESCRIPTION ON THE FACE OF THIS WARRANTY. This warranty and the obligations and liabilities of Flowline under it are exclusive and instead of, and the original purchaser hereby waives, all other remedies, warranties, guarantees or liabilities, express or implied. EXCLUDED FROM THIS WARRANTY IS THE IMPLIED WARRANTY OF FITNESS OF THE PRODUCTS FOR A PARTICULAR PURPOSE OR USE AND THE IMPLIED WARRANTY OF MERCHANT ABILITY OF THE PRODUCTS.

This warranty may not be extended, altered or varied except by a written instrument signed by a duly authorized officer of Flowline, Inc.

Warranty, Service & Repair

To register your product with the manufacturer, go to the Flowline website for on-line registration. The website address is as follows:

www.flowline.com.

On-line Warranty Registration can be found under Contact Us is the Navigation Bar along the side of the home page.

If for some reason your product must be returned for factory service, contact Flowline Inc. at (562) 598-3015 to receive a Material Return Authorization number (MRA), providing the following information:

1. Part Number, Serial Number
2. Name and telephone number of someone who can answer technical questions related to the product and its application.
3. Return Shipping Address
4. Brief Description of the Symptom
5. Brief Description of the Application

Once you have received a Material Return Authorization number, ship the product prepaid in its original packing to:

Flowline Factory Service
MRA _____
10500 Humbolt Street
Los Alamitos, CA 90720

To avoid delays in processing your repair, write the MRA on the shipping label. Please include the information about the malfunction with your product. This information enables our service technicians to process your repair order as quickly as possible.



Getting Started

When powering up the EchoPump, the display will prompt the end user to select either U.S. or Metric units. Press ENTER to select the units for measurement or press MODE to continue with the existing units. EchoPump is configured in U.S. units. If no button is pressed after 15 seconds, the EchoPump will proceed in the last programmed units.

Before you begin the programming of the EchoPump, please determine if the display units will show level or volume. Level units are either in inches for U.S. or cm for metric. Volume units are either in Gallons for U.S. or liters for metric.

Next, measure the distance from the bottom of the tank to the bottom of the transmitter. This value will be the Tank Maximum Depth. This established the maximum operational range that the EchoPump will operate within.



Subsequently, choose the type of relay operation required for the application. There are two types of relay operation, Pump Mode and Independent Mode

Pump Mode Functions	Independent Mode Functions
Alternating Lead/Lag Duplexing High Alarm Low Alarm Out of Bounds Latching	High Alarm Low Alarm Out of Bounds Latching

For programming Pump Mode Functions in level units, go to page 4. For programming Independent Mode Functions in level units, go to page 15.

Table of Contents

Programming the Maximum Depth of the Tank	3
Factory Reset.....	3
Setting Up the Relays.....	3
Pump Mode.....	4
Hysteresis.....	4
Advanced Functions	
Alternating	4
Lead/Lag	5
Duplexing.....	5
Relay Independent Functions	
High Alarm	6
Low Alarm	6
Out of Bounds	6
Latching	6
Invert Logic.....	6
Setting Hysteresis for the Relays	7
Setting Alternating Mode.....	8
Setting Lead/Lag Mode	9
Setting Duplexing Mode.....	10
Setting Relay as a High Level Alarm	11
Setting Relay as a Low Level Alarm	12
Setting Relay as a Out of Bounds Alarm.....	13
Setting Relay as a Latching Relay	14
Independent Mode	15
Hysteresis	15
Relay Functions	
High Alarm	15
Low Alarm	15
Out of Bounds.....	15
Latching	15
Invert Logic	15
Setting Hysteresis for the Relays	16
Setting Relay as a High Level Alarm	16
Setting Relay as a Low Level Alarm	17
Setting Relay as a Out of Bounds Alarm.....	18
Setting Relay as a Latching Relay	19
Safe Mode	20
Calibrating the 4-20 mA Repeater Output.....	21
Digital Calibration	21
Target Calibration	22
Wiring Transmitter to Controller	23
Changing from 120 VAC to 240 VAC.....	24



Programming the Maximum Depth of the Tank

The Maximum Depth setting identifies the height of the tank for the EchoPump. Maximum Depth is a filter, which indicates the maximum range that the transmitter will look for a valid return signal. The EchoPump will never read a level greater than Maximum Depth. Typical applications set Maximum Depth to the distance from the bottom of the tank to the bottom of the transducer.

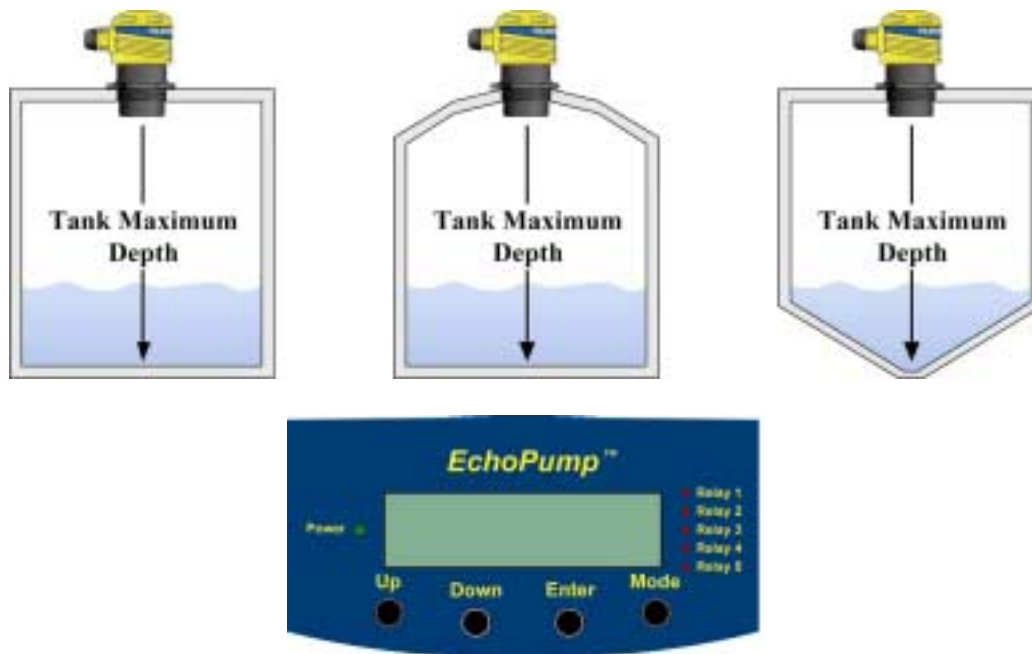

1. Press MODE until “Measurement Mode” appears, then press ENTER.
2. Press MODE until “Tank Maximum Depth” appears, then press ENTER.
3. Use the UP and DOWN buttons to change the displayed value to the measured DC4 setting, then press ENTER to write the value to memory.
4. Press MODE until “Higher Menu Level” appears, then press ENTER.
5. Press MODE until “Exit Keyboard” appears, then press ENTER.

Factory Reset

EchoPump can be reset to its original settings as shipped from the factory. To reset the controller, first remove power to the LC60 series controller. Press and hold ENTER and MODE while adding power back to the controller. When the display becomes active, release ENTER and MODE and wait until the display indicates the level reading.

Setting Up the Relays

EchoPump has two modes of relay logic, Pump Mode and Independent Mode. Pump Mode enables the EchoPump to perform advance functions such as alternating and duplexing on relays 1 and 2 as well as standard functions such as alarms and latching on relays 3 and 4. Independent Mode enables all 4 relays to perform the standard relay functions. It is important to choose the correct mode for your application.

Pump Mode

This mode enables relays 1 and 2 to perform advance pump functions while relays 3 and 4 acting as independent relays. Advanced relay functions include Alternating Mode, Lead/Lag Mode and Duplexing Mode. Independent relay functions include high alarm, low alarm, out of bounds or latching relays. Each relay can also be configured Normally Open or Normally Closed.

Hysteresis – Used to add a differential in level, preventing the relay from chattering. The hysteresis can vary from 0.0” to as high as 10.0”.

Advanced Functions

Alternating – Used to switch between relays 1 and 2 while controlling the level between two level set points. This function is typically used to toggle two pumps that are either Automatically Filling or Automatically Emptying a tank.

For example, as an Auto Empty function, Relay 1 will energize when the level is above the high set point. Relay 1 will de-energize only when the level is below the low set point. The next time the level goes above the high set point, Relay 2 will energize. Relay 2 will de-energize only when the level is below the low set point. The next time the level goes above the high set point, Relay 1 will energize. The controller will continue to alternate between Relays 1 and 2 while automatically emptying the tank. Auto Fill applications work in the same fashion, alternating between relays while filling the tank. Alternating requires both a high set point and low set point for calibration.

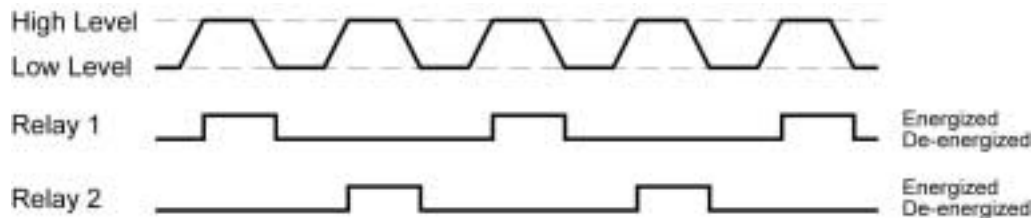



Lead/Lag – Used to control two pumps or valves in an auto fill or auto empty application. The pumps or valves are designated as primary (lead) and secondary (lag). The lead device performs most of the work while the lag device is only used when the lead device cannot handle automatic control. Lead/Lag requires three set points, low set point, high set point and hi-hi set point.

For example, as an Auto Empty function, Relay 1 will energize when the level is above the high set point. Relay 1 will de-energize only when the level is below the low set point. The next time the level goes above the high set point, Relay 1 will energize. If at any time the level goes above the hi-hi set point, then Relay 2 will energize. Both relays will stay energized until the level goes below the Low Set Point. Auto Fill applications work in the same fashion, except the lead relay activates on low set point, the lag relay activates at lo-lo set point and both relays de-activate on high set point.

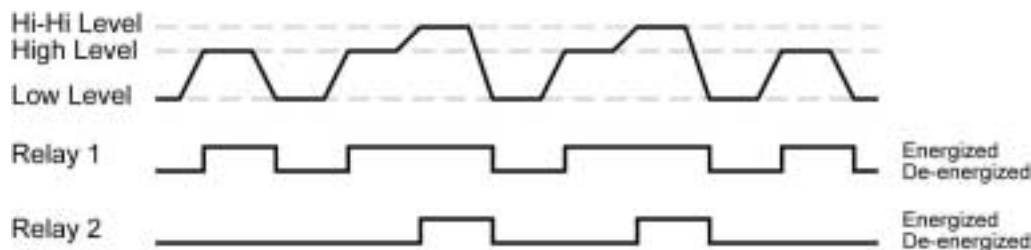

Duplexing – Used to control two pumps or valves in an auto fill or auto empty application in a Lead/Lag operation while alternating between both relays 1 and 2. As in the Lead/Lag Mode, the relays are often identified as Lead and Lag. Duplexing requires three set points, low set point, high set point and hi-hi set point.

For example, in an Auto Empty function, Relay 1 will energize when the level is above the high set point. Relay 2 will only energize when the level is above the hi-hi set point. Both relays will stay energized until the level goes below the low set point. The next time the relay goes above the high set point, Relay 2 energizes. In this state, Relay 1 will only energize when the level goes above the hi-hi set point. As before, both relays will stay energized until the level goes below the low set point. The next time the relay goes above the high set point, Relay 1 will energize. Auto Fill applications work in the same fashion, except the lead relay activates on low set point, the lag relay activates at lo-lo set point and both relays de-activate on high set point.

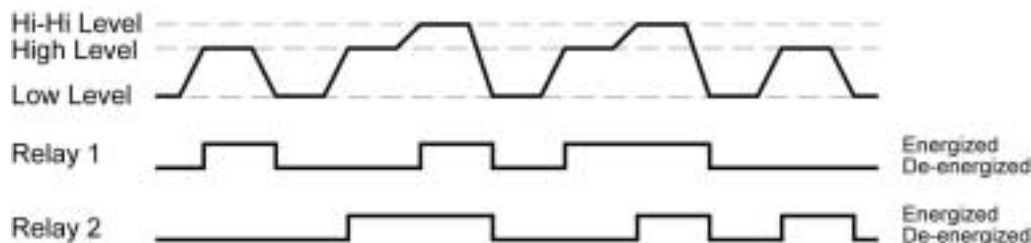

Relay Independent Functions

High Alarm – Used to either energize or de-energize a relay when the level rises above a specified level within the tank. The relay will return to its original state when the level is lower than the specified level. High Alarm requires only one set point near the top of the tank for calibration. Typically used as overflow indication or shut down.

Low Alarm – Similar to High Alarm, except the relay will either energize or de-energize when the level is lower than a specified level in the tank. The relay will return to its original state when the level rises above the specified level. Low Alarm requires only one set point near the top of the tank for calibration. Typically used a low-level pump protection or low inventory level indication.

Out of Bounds – Used to either energize or de-energize a relay when the level either rises above a high set point or lowers below a low set point in the tank. The relay will return to its original state when the level is between the high and low set points. Out of Bounds requires both a high set point and low set point for calibration. This function is typically used a single alarm, which indicates when the level has reach a high or low alarm level.

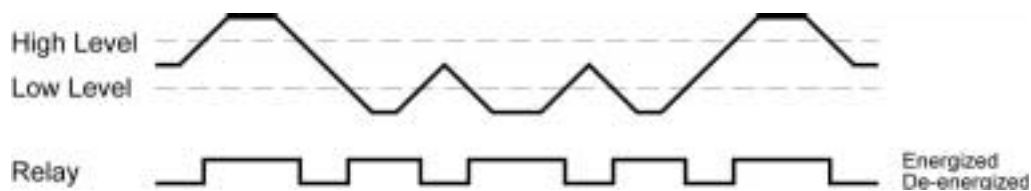

Latching – Used to either energize or de-energize a relay when the level reaches one point and to return to its original state when the level reaches a second level. This function is typically used to either Automatically Fill or Automatically Empty a tank. For example, as an Auto Fill relay, the relay will energize when the level is below the low set point. The relay will not change until the level is above the high set point, then it will de-energize. The relay will stay de-energized until the level is below the low set point, then it will energize again, causing the tank to fill again. As an Auto Empty relay, the relay will energize when the level is above the high set point. The relay will not change until the level is below the low set point, then it will de-energize. The relay will stay de-energized until the level is above the high set point, then it will energize again, causing the tank to empty again. Latching requires both a high set point and low set point for calibration.

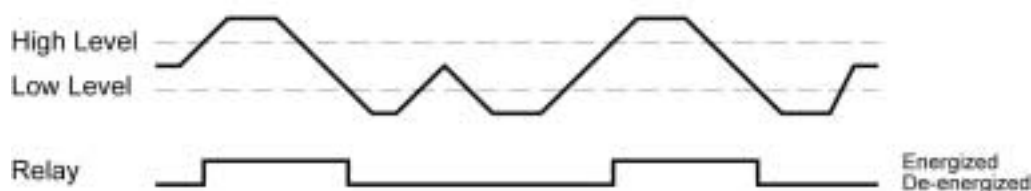

Invert Logic – Enables the normal state of the relay to be set as either energized or de-energized.



Setting Hysteresis for the Relays

The first step in setting Hysteresis is to determine how much of a Hysteresis is required. The Hysteresis is the same for all four relays in the Independent Mode.



1. Press MODE until "Measurement Mode" appears, then press ENTER.
2. Press MODE until "Level Meas. Mode" appears, then press ENTER.
3. Press MODE until "Set Up Relays" appears, then press ENTER.
4. Press MODE until "Relay Hysteresis" appears, then press ENTER.
5. Use the UP and DOWN buttons to change the displayed value to the desired Hysteresis, then press ENTER to write the value to memory.
6. Press MODE until "Higher Menu Level" appears, then press ENTER.
7. Press MODE until "Higher Menu Level" appears, then press ENTER.
8. Press MODE until "Higher Menu Level" appears, then press ENTER.
9. Press MODE until "Exit Keyboard" appears, then press ENTER.
10. Hysteresis has been completed.

Setting Alternating Mode

The first step in setting relays 1 and 2 in Alternating Mode is to determine where the Low Level and High Level set points are in the tank. Once the levels have been determined, measure the distance from the Low Level and High Level set points to the bottom of the transmitter. These will be the Low Set Point and High Set Point respectively. Next, determine if the relay will be de-energized during the fill or empty part of the application. This determines the control capability (auto-fill or auto-empty) of both relays. The relay will switch when the level is below the low set point and above the high set point.



1. Press MODE until “Measurement Mode” appears, then press ENTER.
2. Press MODE until “Level Meas. Mode” appears, then press ENTER.
3. Press MODE until “Set Up Relays” appears, then press ENTER.
4. Press MODE until “Relay Pump Mode” appears, then press ENTER.
5. Press MODE until “Relay Pump Modes” appears, then press ENTER.
6. Press MODE until “High Set Point” appears, then press ENTER.
7. Use the UP and DOWN buttons to change the displayed value to the measured High Set Point, then press ENTER to write the value to memory.
8. Press MODE until “Low Set Point” appears, then press ENTER.
9. Use the UP and DOWN buttons to change the displayed value to the measured Low Set Point, then press ENTER to write the value to memory.
10. Press MODE until “Alternating Mode” appears, then press ENTER.
11. Press MODE until “Higher Menu Level” appears, then press ENTER.
12. Press MODE until “Higher Menu Level” appears, then press ENTER.
13. Press MODE until “Higher Menu Level” appears, then press ENTER.
14. Press MODE until “Higher Menu Level” appears, then press ENTER.
15. Press MODE until “Higher Menu Level” appears, then press ENTER.
16. Press MODE until “Exit Keyboard” appears, then press ENTER.
17. Alternating Mode has been completed.



Setting Lead/Lag Mode

The first step in setting relays 1 and 2 in Lead/Lag Mode is to determine where the High Level, Hi-Hi Level and Low Level set points are in the tank. Once the levels have been determined, measure the distance from the three locations to the bottom of the transmitter. These will be the High Set Point, Hi-Hi Set Point and Low Set Point respectively. Next, determine if the relay will be de-energized during the fill or empty part of the application. This determines the control capability (auto-fill or auto-empty) of both relays. The relay will switch when the level is below the low set point and above the high and hi-hi set points, depending on if it is the lead or lag relay.



1. Press MODE until “Measurement Mode” appears, then press ENTER.
2. Press MODE until “Level Meas. Mode” appears, then press ENTER.
3. Press MODE until “Set Up Relays” appears, then press ENTER.
4. Press MODE until “Relay Pump Mode” appears, then press ENTER.
5. Press MODE until “Relay Pump Modes” appears, then press ENTER.
6. Press MODE until “High Set Point” appears, then press ENTER.
7. Use the UP and DOWN buttons to change the displayed value to the measured High Set Point, then press ENTER to write the value to memory.
8. Press MODE until “Hi Hi Set Point” appears, then press ENTER.
9. Use the UP and DOWN buttons to change the displayed value to the measured Hi Hi Set Point, then press ENTER to write the value to memory.
10. Press MODE until “Low Set Point” appears, then press ENTER.
11. Use the UP and DOWN buttons to change the displayed value to the measured Low Set Point, then press ENTER to write the value to memory.
12. Press MODE until “Lead/Lag Mode” appears, then press ENTER.
13. Press MODE until “Higher Menu Level” appears, then press ENTER.
14. Press MODE until “Higher Menu Level” appears, then press ENTER.
15. Press MODE until “Higher Menu Level” appears, then press ENTER.
16. Press MODE until “Higher Menu Level” appears, then press ENTER.
17. Press MODE until “Higher Menu Level” appears, then press ENTER.
18. Press MODE until “Exit Keyboard” appears, then press ENTER.
19. Lead/Lag Mode has been completed.

Setting Duplexing Mode

The first step in setting relays 1 and 2 in the Duplexing Mode is to determine where the High Level, Hi-Hi Level and Low Level set points are in the tank. Once the levels have been determined, measure the distance from the three locations to the bottom of the transmitter. These will be the High Set Point, Hi-Hi Set Point and Low Set Point respectively. Next, determine if the relay will be de-energized during the fill or empty part of the application. This determines the control capability (auto-fill or auto-empty) of both relays. The relay will switch when the level is below the low set point and above the high and hi-hi set points, depending on if it is the lead or lag relay in the Duplexing Mode.



1. Press MODE until "Measurement Mode" appears, then press ENTER.
2. Press MODE until "Level Meas. Mode" appears, then press ENTER.
3. Press MODE until "Set Up Relays" appears, then press ENTER.
4. Press MODE until "Relay Pump Mode" appears, then press ENTER.
5. Press MODE until "Relay Pump Modes" appears, then press ENTER.
6. Press MODE until "High Set Point" appears, then press ENTER.
7. Use the UP and DOWN buttons to change the displayed value to the measured High Set Point, then press ENTER to write the value to memory.
8. Press MODE until "Hi Hi Set Point" appears, then press ENTER.
9. Use the UP and DOWN buttons to change the displayed value to the measured Hi Hi Set Point, then press ENTER to write the value to memory.
10. Press MODE until "Low Set Point" appears, then press ENTER.
11. Use the UP and DOWN buttons to change the displayed value to the measured Low Set Point, then press ENTER to write the value to memory.
12. Press MODE until "Duplexing Mode" appears, then press ENTER.
13. Press MODE until "Higher Menu Level" appears, then press ENTER.
14. Press MODE until "Higher Menu Level" appears, then press ENTER.
15. Press MODE until "Higher Menu Level" appears, then press ENTER.
16. Press MODE until "Higher Menu Level" appears, then press ENTER.
17. Press MODE until "Higher Menu Level" appears, then press ENTER.
18. Press MODE until "Exit Keyboard" appears, then press ENTER.
19. Lead/Lag Mode has been completed.



Setting Relay as a High Level Alarm

The first step in setting the High Alarm is to determine where the High Level Alarm will activate in the tank. Once the level has been determined, measure the distance from the High Alarm set point to the bottom of the transmitter. Next, determine if the relay will be energized or de-energized when the level is below the High Alarm set point. This is considered the normal state of the relay. The relay will switch when the level is above the high set point.



1. Press MODE until “Measurement Mode” appears, then press ENTER.
2. Press MODE until “Level Meas. Mode” appears, then press ENTER.
3. Press MODE until “Set Up Relays” appears, then press ENTER.
4. Press MODE until “Relay Pump Mode” appears, then press ENTER.
5. Press MODE until “Relay Independent Mode” appears, then press ENTER.
6. Press MODE until the chosen relay (3 or 4) appears, then press ENTER.
7. Press MODE until “High Set Point” appears, then press ENTER.
8. Use the UP and DOWN buttons to change the displayed value to the measured High Alarm set point, then press ENTER to write the value to memory.
9. Press MODE until “Ind. High Mode” appears, then press ENTER.

Relay is now in the High Alarm Mode. The second line of text will indicate the relay number, the state of the relay (“Norm”) and that this function is “Enabled”. To invert relay, go to step 9. To leave the relay in its current state, go to step 10.

10. To invert the relay (“Inv”), press MODE until “Invert Logic” appears, then press ENTER.
11. Press MODE until “Higher Menu Level” appears, then press ENTER.
12. Press MODE until “Higher Menu Level” appears, then press ENTER.
13. Press MODE until “Higher Menu Level” appears, then press ENTER.
14. Press MODE until “Higher Menu Level” appears, then press ENTER.
15. Press MODE until “Higher Menu Level” appears, then press ENTER.
16. Press MODE until “Exit Keyboard” appears, then press ENTER.
17. High Alarm has been completed.

Setting Relay as a Low Level Alarm

The first step in setting the Low Alarm is to determine where the Low Level Alarm will activate in the tank. Once the level has been determined, measure the distance from the Low Alarm set point to the bottom of the transmitter. Next, determine if the relay will be energized or de-energized when the level is above the Low Alarm set point. This is considered the normal state of the relay. The relay will switch when the level is below the low set point.



1. Press MODE until “Measurement Mode” appears, then press ENTER.
2. Press MODE until “Level Meas. Mode” appears, then press ENTER.
3. Press MODE until “Set Up Relays” appears, then press ENTER.
4. Press MODE until “Relay Pump Mode” appears, then press ENTER.
5. Press MODE until “Relay Independent Mode” appears, then press ENTER.
6. Press MODE until the chosen relay (3 or 4) appears, then press ENTER.
7. Press MODE until “Low Set Point” appears, then press ENTER.
8. Use the UP and DOWN buttons to change the displayed value to the measured Low Alarm set point, then press ENTER to write the value to memory.
9. Press MODE until “Ind. Low Mode” appears, then press ENTER.

Relay is now in the Low Alarm Mode. The second line of text will indicate the relay number, the state of the relay (“Norm”) and that this function is “Enabled”. To invert relay, go to step 9. To leave the relay in its current state, go to step 10.

10. To invert the relay (“Inv”), press MODE until “Invert Logic” appears, then press ENTER.
11. Press MODE until “Higher Menu Level” appears, then press ENTER.
12. Press MODE until “Higher Menu Level” appears, then press ENTER.
13. Press MODE until “Higher Menu Level” appears, then press ENTER.
14. Press MODE until “Higher Menu Level” appears, then press ENTER.
15. Press MODE until “Higher Menu Level” appears, then press ENTER.
16. Press MODE until “Exit Keyboard” appears, then press ENTER.
17. Low Alarm has been completed.



Setting Relay as Out of Bounds Relay

The first step in setting the relay as an Out of Bounds relay is to determine where the Low Level and High Level set points are in the tank. Once the levels have been determined, measure the distance from the Low Level and High Level set points to the bottom of the transmitter. These will be the Low Set Point and High Set Point respectively. Next, determine if the relay will be energized or de-energized when the level is between the Low and High set points. This is considered the normal state of the relay. The relay will switch when the level is below the low set point and above the high set point.



1. Press MODE until "Measurement Mode" appears, then press ENTER.
2. Press MODE until "Level Meas. Mode" appears, then press ENTER.
3. Press MODE until "Set Up Relays" appears, then press ENTER.
4. Press MODE until "Relay Pump Mode" appears, then press ENTER.
5. Press MODE until "Relay Independent Mode" appears, then press ENTER.
6. Press MODE until the chosen relay (3 or 4) appears, then press ENTER.
7. Press MODE until "High Set Point" appears, then press ENTER.
8. Use the UP and DOWN buttons to change the displayed value to the measured High Set Point, then press ENTER to write the value to memory.
9. Press MODE until "Low Set Point" appears, then press ENTER.
10. Use the UP and DOWN buttons to change the displayed value to the measured Low Set Point, then press ENTER to write the value to memory.
11. Press MODE until "Ind. Hi/Low Mode" appears, then press ENTER.

Relay is now in the Out of Bounds Mode "Ind. Hi/Low Mode". The second line of text will indicate the relay number, the state of the relay ("Norm") and that this function is "Enabled". To invert relay, go to step 11. To leave the relay in its current state, go to step 12.

12. To invert the relay ("Inv"), press MODE until "Invert Logic" appears, then press ENTER.
13. Press MODE until "Higher Menu Level" appears, then press ENTER.
14. Press MODE until "Higher Menu Level" appears, then press ENTER.
15. Press MODE until "Higher Menu Level" appears, then press ENTER.
16. Press MODE until "Higher Menu Level" appears, then press ENTER.
17. Press MODE until "Higher Menu Level" appears, then press ENTER.
18. Press MODE until "Exit Keyboard" appears, then press ENTER.
19. Out of Bounds has been completed.

Setting Relay as Latching Relay

The first step in setting the relay as a Latching relay is to determine where the Low Level and High Level set points are in the tank. Once the levels have been determined, measure the distance from the Low Level and High Level set points to the bottom of the transmitter. These will be the Low Set Point and High Set Point respectively. Next, determine if the relay will be energized or de-energized when the level is between the Low and High set points. This is considered the normal state of the relay. The relay will switch when the level is below the low set point and above the high set point.



1. Press MODE until “Measurement Mode” appears, then press ENTER.
2. Press MODE until “Level Meas. Mode” appears, then press ENTER.
3. Press MODE until “Set Up Relays” appears, then press ENTER.
4. Press MODE until “Relay Pump Mode” appears, then press ENTER.
5. Press MODE until “Relay Independent Mode” appears, then press ENTER.
6. Press MODE until the chosen relay (3 or 4) appears, then press ENTER.
7. Press MODE until “High Set Point” appears, then press ENTER.
8. Use the UP and DOWN buttons to change the displayed value to the measured High Set Point, then press ENTER to write the value to memory.
9. Press MODE until “Low Set Point” appears, then press ENTER.
10. Use the UP and DOWN buttons to change the displayed value to the measured Low Set Point, then press ENTER to write the value to memory.
11. Press MODE until “Ind. Latch Mode” appears, then press ENTER.

Relay is now in the Latching Mode. The second line of text will indicate the relay number, the state of the relay (“Norm”) and that this function is “Enabled”. To invert relay, go to step 11. To leave the relay in its current state, go to step 12.

12. To invert the relay (“Inv”), press MODE until “Invert Logic” appears, then press ENTER.
13. Press MODE until “Higher Menu Level” appears, then press ENTER.
14. Press MODE until “Higher Menu Level” appears, then press ENTER.
15. Press MODE until “Higher Menu Level” appears, then press ENTER.
16. Press MODE until “Higher Menu Level” appears, then press ENTER.
17. Press MODE until “Higher Menu Level” appears, then press ENTER.
18. Press MODE until “Exit Keyboard” appears, then press ENTER.
19. Latching has been completed.

Independent Mode



This mode enables all four relays to act independent of each other. Each relay can be set as either a high alarm, low alarm, out of bounds or latching relay. Each relay can also be configured Normally Open or Normally Closed.

Hysteresis – Used to add a differential in level, preventing the relay from chattering. The hysteresis can vary from 0.0” to as high as 10.0”.

High Alarm – Used to either energize or de-energize a relay when the level rises above a specified level within the tank. The relay will return to its original state when the level is lower than the specified level. High Alarm requires only one set point near the top of the tank for calibration. Typically used as overflow indication or shut down.

Low Alarm – Similar to High Alarm, except the relay will either energize or de-energize when the level is lower than a specified level in the tank. The relay will return to its original state when the level rises above the specified level. Low Alarm requires only one set point near the top of the tank for calibration. Typically used a low-level pump protection or low inventory level indication.

Out of Bounds – Used to either energize or de-energize a relay when the level either rises above a high set point or lowers below a low set point in the tank. The relay will return to its original state when the level is between the high and low set points. Out of Bounds requires both a high set point and low set point for calibration. This function is typically used a single alarm, which indicates when the level has reach a high or low alarm level.

Latching – Used to either energize or de-energize a relay when the level reaches one point and to return to its original state when the level reaches a second level. This function is typically used to either Automatically Fill or Automatically Empty a tank. For example, as an Auto Fill relay, the relay will energize when the level is below the low set point. The relay will not change until the level is above the high set point, then it will de-energize. The relay will stay de-energized until the level is below the low set point, then it will energize again, causing the tank to fill again. As an Auto Empty relay, the relay will energize when the level is above the high set point. The relay will not change until the level is below the low set point, then it will de-energize. The relay will stay de-energized until the level is above the high set point, then it will energize again, causing the tank to empty again. Latching requires both a high set point and low set point for calibration.

Invert Logic – Enables the normal state of the relay to be set as either energized or de-energized.

Setting Hysteresis for the Relays

The first step in setting Hysteresis is to determine how much of a Hysteresis is required. The Hysteresis is the same for all four relays in the Independent Mode.



1. Press MODE until “Measurement Mode” appears, then press ENTER.
2. Press MODE until “Level Meas. Mode” appears, then press ENTER.
3. Press MODE until “Set Up Relays” appears, then press ENTER.
4. Press MODE until “Relay Hysteresis” appears, then press ENTER.
5. Use the UP and DOWN buttons to change the displayed value to the desired Hysteresis, then press ENTER to write the value to memory.
6. Press MODE until “Higher Menu Level” appears, then press ENTER.
7. Press MODE until “Higher Menu Level” appears, then press ENTER.
8. Press MODE until “Higher Menu Level” appears, then press ENTER.
9. Press MODE until “Exit Keyboard” appears, then press ENTER.
10. Hysteresis has been completed.

Setting Relay as a High Level Alarm

The first step in setting the High Alarm is to determine where the High Level Alarm will activate in the tank. Once the level has been determined, measure the distance from the High Alarm set point to the bottom of the transmitter. Next, determine if the relay will be energized or de-energized when the level is below the High Alarm set point. This is considered the normal state of the relay. The relay will switch when the level is above the high set point.

1. Press MODE until “Measurement Mode” appears, then press ENTER.
2. Press MODE until “Level Meas. Mode” appears, then press ENTER.
3. Press MODE until “Set Up Relays” appears, then press ENTER.
4. Press MODE until “Independent Mode” appears, then press ENTER.
5. Press MODE until the chosen relay (1 through 4) appears, then press ENTER.
6. Press MODE until “High Set Point” appears, then press ENTER.
7. Use the UP and DOWN buttons to change the displayed value to the measured High Alarm set point, then press ENTER to write the value to memory.
8. Press MODE until “Ind. High Mode” appears, then press ENTER.

Relay is now in the High Alarm Mode. The second line of text will indicate the relay number, the state of the relay (“Norm”) and that this function is “Enabled”. To invert relay, go to step 9. To leave the relay in its current state, go to step 10.



9. To invert the relay (“Inv”), press MODE until “Invert Logic” appears, then press ENTER.
10. Press MODE until “Higher Menu Level” appears, then press ENTER.
11. Press MODE until “Higher Menu Level” appears, then press ENTER.
12. Press MODE until “Higher Menu Level” appears, then press ENTER.
13. Press MODE until “Higher Menu Level” appears, then press ENTER.
14. Press MODE until “Exit Keyboard” appears, then press ENTER.
15. High Alarm has been completed.

Setting Relay as a Low Level Alarm

The first step in setting the Low Alarm is to determine where the Low Level Alarm will activate in the tank. Once the level has been determined, measure the distance from the Low Alarm set point to the bottom of the transmitter. Next, determine if the relay will be energized or de-energized when the level is above the Low Alarm set point. This is considered the normal state of the relay. The relay will switch when the level is below the low set point.



1. Press MODE until “Measurement Mode” appears, then press ENTER.
2. Press MODE until “Level Meas. Mode” appears, then press ENTER.
3. Press MODE until “Set Up Relays” appears, then press ENTER.
4. Press MODE until “Independent Mode” appears, then press ENTER.
5. Press MODE until the chosen relay (1 through 4) appears, then press ENTER.
6. Press MODE until “Low Set Point” appears, then press ENTER.
7. Use the UP and DOWN buttons to change the displayed value to the measured Low Alarm set point, then press ENTER to write the value to memory.
8. Press MODE until “Ind. Low Mode” appears, then press ENTER.

Relay is now in the Low Alarm Mode. The second line of text will indicate the relay number, the state of the relay (“Norm”) and that this function is “Enabled”. To invert relay, go to step 9. To leave the relay in its current state, go to step 10.

9. To invert the relay (“Inv”), press MODE until “Invert Logic” appears, then press ENTER.
10. Press MODE until “Higher Menu Level” appears, then press ENTER.
11. Press MODE until “Higher Menu Level” appears, then press ENTER.
12. Press MODE until “Higher Menu Level” appears, then press ENTER.
13. Press MODE until “Higher Menu Level” appears, then press ENTER.
14. Press MODE until “Exit Keyboard” appears, then press ENTER.

15. Low Alarm has been completed.

Setting Relay as Out of Bounds Relay

The first step in setting the relay as an Out of Bounds relay is to determine where the Low Level and High Level set points are in the tank. Once the levels have been determined, measure the distance from the Low Level and High Level set points to the bottom of the transmitter. These will be the Low Set Point and High Set Point respectively. Next, determine if the relay will be energized or de-energized when the level is between the Low and High set points. This is considered the normal state of the relay. The relay will switch when the level is below the low set point and above the high set point.



1. Press MODE until “Measurement Mode” appears, then press ENTER.
2. Press MODE until “Level Meas. Mode” appears, then press ENTER.
3. Press MODE until “Set Up Relays” appears, then press ENTER.
4. Press MODE until “Independent Mode” appears, then press ENTER.
5. Press MODE until the chosen relay (1 through 4) appears, then press ENTER.
6. Press MODE until “High Set Point” appears, then press ENTER.
7. Use the UP and DOWN buttons to change the displayed value to the measured High Set Point, then press ENTER to write the value to memory.
8. Press MODE until “Low Set Point” appears, then press ENTER.
9. Use the UP and DOWN buttons to change the displayed value to the measured Low Set Point, then press ENTER to write the value to memory.
10. Press MODE until “Ind. Hi/Low Mode” appears, then press ENTER.

Relay is now in the Out of Bounds Mode “Ind. Hi/Low Mode”. The second line of text will indicate the relay number, the state of the relay (“Norm”) and that this function is “Enabled”. To invert relay, go to step 11. To leave the relay in its current state, go to step 12.

11. To invert the relay (“Inv”), press MODE until “Invert Logic” appears, then press ENTER.
12. Press MODE until “Higher Menu Level” appears, then press ENTER.
13. Press MODE until “Higher Menu Level” appears, then press ENTER.
14. Press MODE until “Higher Menu Level” appears, then press ENTER.
15. Press MODE until “Higher Menu Level” appears, then press ENTER.
16. Press MODE until “Exit Keyboard” appears, then press ENTER.
17. Out of Bounds has been completed.



Setting Relay as Latching Relay

The first step in setting the relay as a Latching relay is to determine where the Low Level and High Level set points are in the tank. Once the levels have been determined, measure the distance from the Low Level and High Level set points to the bottom of the transmitter. These will be the Low Set Point and High Set Point respectively. Next, determine if the relay will be energized or de-energized when the level is between the Low and High set points. This is considered the normal state of the relay. The relay will switch when the level is below the low set point and above the high set point.



1. Press MODE until “Measurement Mode” appears, then press ENTER.
2. Press MODE until “Level Meas. Mode” appears, then press ENTER.
3. Press MODE until “Set Up Relays” appears, then press ENTER.
4. Press MODE until “Independent Mode” appears, then press ENTER.
5. Press MODE until the chosen relay (1 through 4) appears, then press ENTER.
6. Press MODE until “High Set Point” appears, then press ENTER.
7. Use the UP and DOWN buttons to change the displayed value to the measured High Set Point, then press ENTER to write the value to memory.
8. Press MODE until “Low Set Point” appears, then press ENTER.
9. Use the UP and DOWN buttons to change the displayed value to the measured Low Set Point, then press ENTER to write the value to memory.
10. Press MODE until “Ind. Latch Mode” appears, then press ENTER.

Relay is now in the Latching Mode. The second line of text will indicate the relay number, the state of the relay (“Norm”) and that this function is “Enabled”. To invert relay, go to step 11. To leave the relay in its current state, go to step 12.

11. To invert the relay (“Inv”), press MODE until “Invert Logic” appears, then press ENTER.
12. Press MODE until “Higher Menu Level” appears, then press ENTER.
13. Press MODE until “Higher Menu Level” appears, then press ENTER.
14. Press MODE until “Higher Menu Level” appears, then press ENTER.
15. Press MODE until “Higher Menu Level” appears, then press ENTER.
16. Press MODE until “Exit Keyboard” appears, then press ENTER.
17. Latching has been completed.

Safe Mode

The transmitter continuously sends out sound pulses and measures the time of flight for the return pulses. If the conditions of the tank or the application prevent the sound pulses from returning to the transmitter, the controller will enter a LOST mode. When this occurs, Relay 5 will energize. In addition, the remaining four relays (Relays 1 through 4) can be preset to either energize or de-energize during the LOST mode. When choosing the LOST state of each relay, take into consideration the devices the relays are connected to. For example, if a pump used to auto-fill a tank is connected to Relay 1, choose the correct state, which would prevent the pump from over filling the tank. The three states are Safe Modes 0, 1 or 2. Safe Mode 0 does not change the state of the relay. Safe Mode 1 energizes the relay while Safe Mode 2 de-energizes the relay.



1. Press MODE until "Measurement Mode" appears, then press ENTER.
2. Press MODE until "Level Meas. Mode" appears, then press ENTER.
3. Press MODE until "Set Up Relays" appears, then press ENTER.
4. Press MODE until "Safe Mode" appears, then press ENTER.
5. Press MODE until the chosen relay (1 through 4) appears, then press ENTER.
6. Use the UP and DOWN buttons to change the displayed value to either Safe Mode 0, 1 or 2, then press ENTER to write the value to memory.
7. Press MODE until "Higher Menu Level" appears, then press ENTER.
8. Press MODE until "Higher Menu Level" appears, then press ENTER.
9. Press MODE until "Higher Menu Level" appears, then press ENTER.
10. Press MODE until "Higher Menu Level" appears, then press ENTER.
11. Press MODE until "Exit Keyboard" appears, then press ENTER.
12. Safe Mode has been completed.



Calibrating the 4-20 mA Repeater Output

The settings for the 4 mA and 20 mA settings can be programmed in two different methods. The first method, Digital Calibration, requires both settings to be known measured values from the bottom of the transducer to their respected level in the tank. The liquid in the tank can be at any level within the 4-20 mA range. The second method, Target Calibration, requires the level to be physically set to the 4mA and 20 mA levels for calibration.

Digital Calibration

The first step in Digital Calibration is to determine where the 4mA and 20 mA settings are going to be in the tank. Once the levels have been determined, measure the distance from each level to the bottom of the transmitter. The values will be known as DC4 (4 mA setting) and DC20 (20 mA setting). The DC4 and DC20 values are ideally set such that DC4 is a larger value (representing an empty tank) and DC20 a smaller value (representing a full tank). The DC4 and DC20 values can be reversed, indicating a decrease in current as the liquid rises in the tank. Program each value to its respective setting (DC4 and DC20).



1. Press MODE until "Measurement Mode" appears, then press ENTER.
2. Press MODE until "Level Meas. Mode" appears, then press ENTER.
3. Press MODE until "Set Up 4-20 mA Out." appears, then press ENTER.
4. Press MODE until "DC 4 mA Value" appears, then press ENTER.
5. Use the UP and DOWN buttons to change the displayed value to the measured DC4 setting, and then press ENTER to write the value to memory.
6. Press MODE until "DC 20 mA Value" appears, then press ENTER.
7. Use the UP and DOWN buttons to change the displayed value to the measured DC20 setting, and then press ENTER to write the value to memory.
8. Press MODE until "Higher Menu Level" appears, then press ENTER.
9. Press MODE until "Higher Menu Level" appears, then press ENTER.
10. Press MODE until "Higher Menu Level" appears, then press ENTER.
11. Press MODE until "Exit Keyboard" appears, then press ENTER.
12. Digital Calibration has been completed.

Target Calibration

The first step in Target Calibration is to determine where the 4mA and 20 mA settings are going to be in the tank. Once the levels have been determined, adjust the level in the tank to 4mA level of liquid.



1. Press MODE until “Measurement Mode” appears, then press ENTER.
2. Press MODE until “Level Meas. Mode” appears, then press ENTER.
3. Press MODE until “Set Up 4-20 mA Out.” appears, then press ENTER.
4. Press MODE until “EC 4 mA Value” appears, then press ENTER.
5. Press ENTER to write the value to memory.
6. Press MODE until “Higher Menu Level” appears, then press ENTER.
7. Press MODE until “Higher Menu Level” appears, then press ENTER.
8. Press MODE until “Higher Menu Level” appears, then press ENTER.
9. Press MODE until “Exit Keyboard” appears, then press ENTER.
10. Target Calibration for the 4 mA level has been completed.

Now adjust the level in the tank to the 20 mA level of liquid.

1. Press MODE until “Measurement Mode” appears, then press ENTER.
2. Press MODE until “Level Meas. Mode” appears, then press ENTER.
3. Press MODE until “Set Up 4-20 mA Out.” appears, then press ENTER.
4. Press MODE until “EC 20 mA Value” appears, then press ENTER.
5. Press ENTER to write the value to memory.
6. Press MODE until “Higher Menu Level” appears, then press ENTER.
7. Press MODE until “Higher Menu Level” appears, then press ENTER.
8. Press MODE until “Higher Menu Level” appears, then press ENTER.
9. Press MODE until “Exit Keyboard” appears, then press ENTER.
10. Target Calibration for the 20 mA level has been completed.

In Target Calibration, either the 4 mA or 20 mA settings can be set first and can be adjusted at any time as long as the level in the tank matches the correct level for either the 4mA or 20 mA setting. The transmitter may also be placed outside of the tank at a know distance to a flat object to match either the 4 mA or 20 mA settings.



Wiring Transmitter to Controller

Follow the diagram below for identifying the terminals and connections for the transmitter and controller:

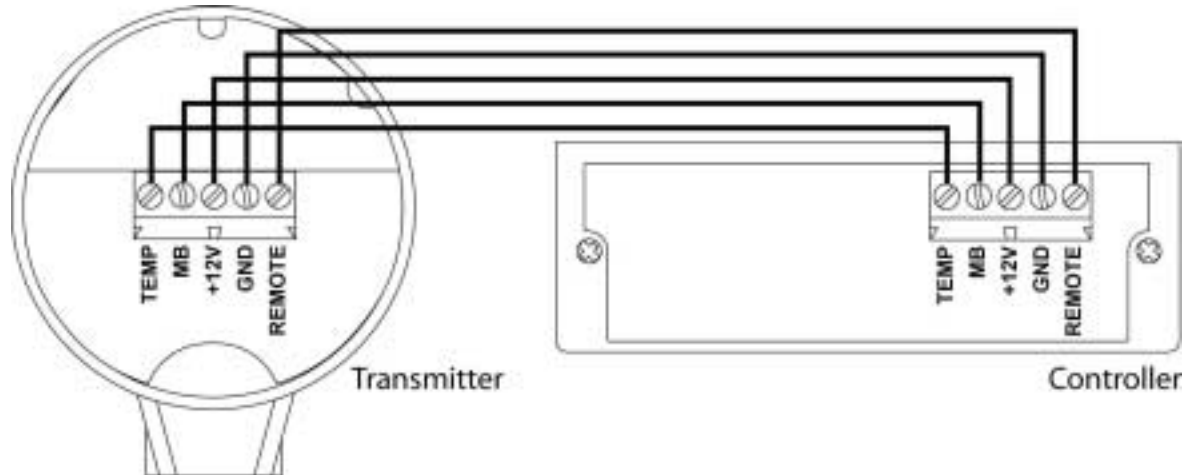

General Relay Wiring

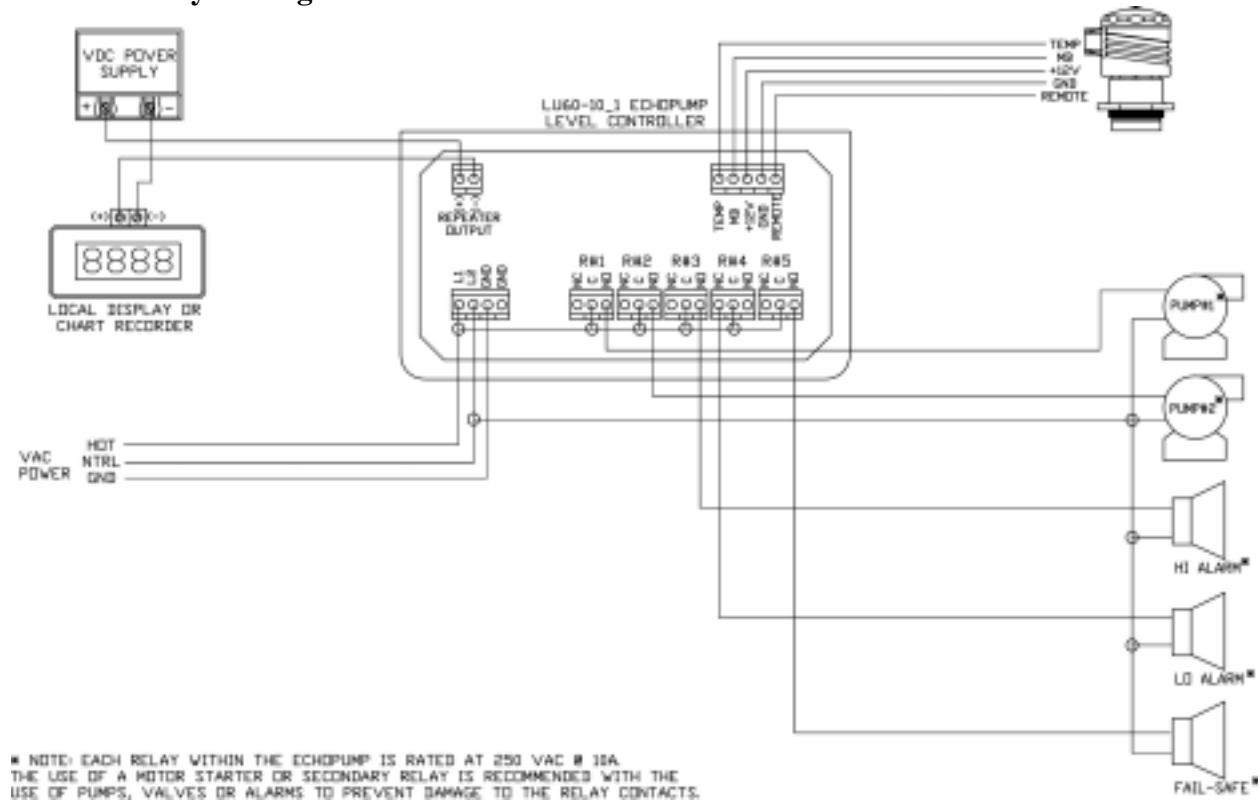

Changing from 120 VAC to 240 VAC

To change the LU60 from 120 VAC to 240 VAC, simply follow the instruction below.

1. Remove power to the LU60
2. Remove the four screws located in the top enclosure.



3. Gently remove the cover and Printed Circuit Board (PCB) from the enclosure.
4. Look for a series of two jumpers labeled JW1 and JW2
5. Change both jumpers (JW1 and JW2) from their A to their B positions.

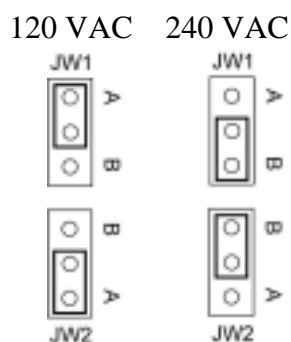

Position A is for 120 VAC, position B is for 240 VAC.

6. Return the PCB and cover to the enclosure
7. Attach the four screws to the enclosure